

Model RM5000 Telephone Interface

Confidentiality Notice

This manual is provided solely as an operational, installation, and maintenance guide and contains sensitive business and technical information that is confidential and proprietary to our company. We retain all intellectual property and other rights in or to the information contained herein, and such information may only be used in connection with the operation of this product or system.

This manual may not be disclosed in any form, in whole or in part, directly or indirectly, to any third party.

General Information

The RM5000 Telephone Interface has been specifically designed to interface an RM5000 Ringmaster Intercom system to a two wire loop start, 600 ohm analogue telephone line. The interface provides additional features such as remote Day/Night switch operation whereby the unit provides automatic transfer of an incoming intercom call to the external telephone line. Call disconnect is also catered for using either a loop disconnect, DTMF disconnect, call time disconnect or dial tone disconnect function whichever may be available depending upon the C.O. exchange. In addition both local or remote (passcode protected) user telephone number programming is provided as well as auto answer enable/bypass. This last feature allows a local parallel telephone to answer incoming calls providing dual functionality to a single telephone line.

The 5.25"W x 3.5"D x 1.6"H aluminium enclosure is designed for desk mounting or else can be wall mounted using the optional wall mount bracket.

The standard version of software installed in the Interface does not allow multiple Interfaces to be installed in parallel, or to be 'party-lined' on the same telephone line, as any such installation can cause programming difficulties, premature disconnection of calls, or Interfaces that may not respond when activated due to excessive line current being drawn. However if such a requirement was required this could be accommodated using our 8 x channel Mincon Telephone Line Concentrator. Minelec Limited recommend that one telephone (PBX extension or C.O. line) be allocated for each required Interface.

The Interface is supplied with 5 x RJ11 telephone boxes and 5 x 12" long interconnecting cables. For industrial wall mount applications these allow remote cables to be easily connected to the Interface.

A front panel mount On-Off button is fitted which switches OFF power to the Interface circuitry while maintaining power to a through going 'bus' arrangement that can be used to power a remote Master Station if required. This switch has a green built-in LED which indicates that the PCB supply is healthy.

A number of other features are provided and these include an additional temporary transfer input that when operated, will switch any incoming call destined for the remote Master Station to the outgoing telephone line, where the call will be processed as programmed.

In addition, a seven segment LED display is provided that indicates the status of the unit when in use, showing 'P' for 'Programming' mode, 'C' for 'Calling' on the telephone line and it also flashes the center bar to indicate the unit has a healthy status. Whenever the power is 'RESET' or the 'RESET' DIP switch is activated, the LED display will sequentially display, digit by digit, the stored telephone number. When the unit detects the called party has hung up it will send the disconnect command to the RM5000 and will indicate the disconnect command on the LED display using the 'o' symbol.

Operation:

In normal mode, with the On/Off switch ON, and the On/Off switch LED OFF, with the Transfer Switch OPEN (GREEN TRANS. SWITCH LED OFF), any incoming Intercom call sent to RM5000 TB-10 station will be routed to the Master Station via the Telephone Interface.

When the Transfer Switch is CLOSED, the ON/OFF switch LED will be ON and the green TRANS. SWITCH LED will be ON. When a remote intercom is activated, the RM5000 routes the call to the telephone interface. The incoming call will be detected by the Interface and the green ACTIVE LED will switch ON. The interface routes the call to the Telephone Line. The Interface will go Off-hook, obtain dial tone and begin to dial the stored telephone number. In this condition, both the TRANS. SWITCH LED and the STATION ACTIVE LED will remain lit and the display will show "C". Once the call has been dialed, the audio circuit is switched from the telephone line to the calling Intercom so that any ring tone generated by the telephone exchange is heard at the calling intercom station. This will continue until the call is either answered

Once the call has been answered, normal two way communication can commence.

Once the call is complete and the called party hangs up their telephone set, the Telephone Interface will receive a loop disconnect signal from the Telephone Exchange and will then issue a disconnect signal to the RM5000 controller and both the Interface and calling Intercom which will be automatically reset. The LED display will indicate "o" to show that it is going on- hook and is disconnecting the system.

The Interface then awaits the next call with the status bar flashing to indicate the system is healthy.

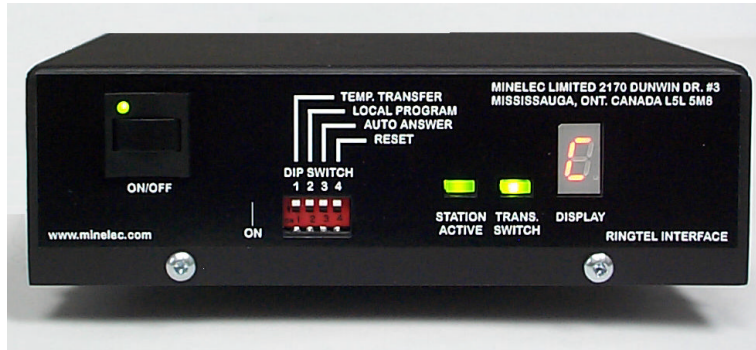

RINGTEL INTERFACE

Installation:

The Interface is very simple to install.

Component list:

- 1 x RM 5000 Telephone Interface
- 1 x Wallmount bracket (Optional)
- 4 x 12" long 4 wire line cords
- 4 x RJ11 terminal boxes

If a wall mount installation is required, install the optional wall mount bracket using (customer supplied) #10 x 3/4" L screws ensuring that the keyhole slots in the front of the bracket are correctly oriented to allow adequate support to the Interface when in the vertical position. The orientation of the Interface itself should be considered in view of the viewing position of the LED or any required access to the cable terminations or configuration of the DIP switches.

The Interface is fitted with two thumbscrew mounts on the rear panel (these also hold the internal PCB in place) and these are designed to fit into the wall mount bracket keyslots which then support the Interface on the bracket.

Mount the supplied RJ11 boxes at suitable locations close to the Interface but within 10" of the Interface itself in order to allow the 12" long line cords to be plugged in. Carefully route the line cords and neatly staple them to the wall or else tie wrap them to suitable cable supports.

Insert a cord into each of the RJ11 sockets on the interface:

- To RM5000
- To Master
- C.O. Line
- Transfer Switch

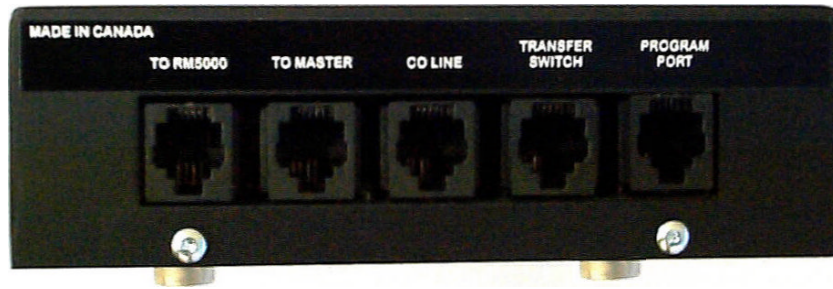

RINGTEL REAR PANEL

Label the RJ11 boxes accordingly

If desk mounting is required, then connect suitable RJ11 cables directly to RJ11 sockets fitted to rear of the Interface enclosure in accordance with the following terminal descriptions and /or appropriate system diagram.

If appropriate turn off the Power Supply from the RM5000 main controller and then remove the front cover from each RJ11 box and wire each connection in accordance with the system requirements.

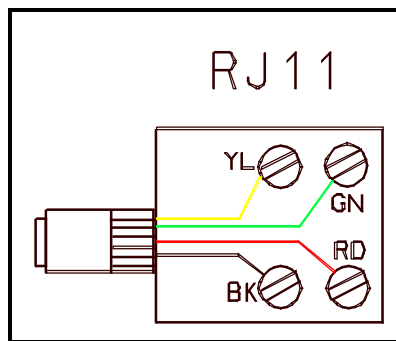

RJ11 terminal connections

1) **To RM5000 :**

This input is connected to the RM5000 main PCB, and is wired as follows:

RM5000 - TB-10	RJ11 Box (#5)*
1 (A)	RD
2 (A)	GN
3 (+)	BK
4 (-ve)	YL
5 (N.U.)	(N.U.)
6 (N.U.)	(N.U.)

* See layout diagram

2) **To Master:**

This input is connected to the Master Station (typically a AA916). When the Interface is not enabled, (Transfer Switch operated) any incoming call will be switched to the Master Station.

KB 171 Box	RJ11 Box (#4)
5 (A) (GN)	RD
4 (A) (RD)	GN
3 (+) (BK)	BK
6 (-ve) (YL)	YL
1 (N.U.)	(N.U.)
2 (N.U.)	(N.U.)

3) **C.O. Line:**

This output is connected to a 48vdc two wire, analogue, loop start, 600 ohm telephone line. The connection is not polarity sensitive.

C.O. Line	RJ11 Box (#3)
Tip (+)	RD
Ring (-)	GN

4) Transfer Switch:

This input is connected to the remote Transfer Switch (Normally a Day/Night keyswitch). A closed contact ENABLES the call transfer process and switches any incoming Intercom call to the telephone line instead of to the Intercom Master Station.

REMOTE DAY/NIGHT TRANSFER SWITCH

N.O.

N.O.

RJ11 Box (#2)

RD

GN

Contact closed to enable transfer.

Once all connections have been checked, switch on the RM5000 Power supply. This will supply 24vdc power to the Interface and to the Master Station (if connected). When first powered up, the LED display should sequentially display digits 1-2 thru 9 - 0 as these are the factory default digits stored in the Eprom during final testing. The system is now ready to be programmed.

Programming Instructions

The RM5000 Telephone Interface allows a number of programming options including both local and remote programming of the required stored telephone number. For remote programming, a touch tone (DTMF) telephone connected to a separate central office (CO) or private branch exchange (PBX) line is required and DIP Sw. #2 should be set OFF and DIP Sw. #3 should be set ON. For local programming, DIP Sw. #2 should be set to ON and DIP Sw. #3 should be set to OFF.

DIP Sw. #4 is used to locally RESET the Interface processor without switching the Power On –Off. One benefit to this is that the Interface has been programmed to sequentially display the stored telephone number whenever the processor first initializes. Therefore operating this switch (On-Off) forces the Interface to sequentially display the stored digits.

Remote Programming

The programming mode is accessed by dialing a four digit programming password. (see the password enabled programming section for details). The programming password is FIXED in memory and cannot be changed. This facility provides an extremely high degree of reliability of gaining access to the programming features when remote accessing the unit as it prevents inadvertent changing or corruption of the passcode - an effect that often prevents programming entry.

The telephone board provides a “*Programming Protection*” feature in that once programming is complete an on-board jumper link P7 can be moved to the “*Program Disabled*” position (cover one pin only). By moving this jumper, NO access can be gained to the programming mode, effectively "locking out" all attempts to remotely change any of the programmed parameters until the link is returned to the “*Program Enabled*” position.

Password Enabled Programming

1. The Interface is factory set with “*Program Protection*” jumper link P1 fitted to allow programming. If it is required for any reason to prevent telephone number re-programming this link may be removed.
2. The Interface must be set to auto-answer an incoming call by setting DIL SW3 to ON .
3. Using a DTMF (touch tone) telephone, place a call to the Interface unit. The Interface will automatically answer on the first ring and will generate an answer tone (single beep) back to the calling phone.
4. Enter the four digit passcode (2468). If all digits are entered correctly the telephone acknowledges with a success tone (single beep) indicating the programming mode has been accessed.

Note:

The telephone will automatically drop off-line if an incorrect Passcode digit is entered. A corresponding error code “E” will be displayed.

5. If the success tone has been generated the display on the unit will also indicate “P” ‘. Begin entering the desired autodial number followed by the DTMF character “*” . If you make a mistake in entering the autodial number press the “#” button and start again.

6. If the digits have been successfully stored a success tone (single beep) is generated and the stored digits will be displayed on the front panel display .
7. Terminate the programming by placing the DTMF telephone on-hook .
8. Reset DIL SW3 to the OFF position to prevent the Interface from answering incoming calls intended for other parallel phones.

Local Programming

Local programming can be carried out by using a standard analogue touch tone phone connected into the local programming port. Select local programming mode by setting DIL SW2 to the ON position.

1. Lift the telephone handset and press the “#” key on the keypad. The display on the front of the interface will indicate “P” to show that the unit is in the programming mode.
2. Enter the required autodial telephone number using the keypad of the telephone and follow it by “*”. If you make a mistake in entering the autodial number press the “#” button and start again.
3. If the new autodial number is accepted it will be displayed digit by digit on the front panel display.
4. Hang up the telephone and disconnect from the programming port.
5. Rest DIL SW2 to the OFF position .
6. The stored number can be displayed at any time by connecting a telephone into the programming port, setting DIL SW1 and SW2 ON and entering *. Alternatively the stored number can be displayed at any time by setting DIL SW1 to ON and setting DIL SW 4 to ON and then OFF. The display will display the stored number. **PLEASE NOTE THAT OPERATING DIL SW1 WILL DISCONNECT THE MASTER INTERCOM UNTIL IT IS SWITCHED OFF.**

Programming the Autodial Number

Autodial Number : Assigns a telephone number to be dialed when the Interface is in transfer mode and an intercom calls the master..

Program Sequence:

xxxx* where xxxx is the required autodial number (up to 12 digits)

(default number:)

eg: 3933555*

The digits that can be entered are DTMF 0 through to 9. The DTMF digits “*” and “#” cannot be used in the autodial number.

Remote Power:

The Interface unit is powered from the RM5000 controller. It is only powered when the Transfer Switch is operated.

Fault Finding:

To take the Interface out of circuit for fault finding remove the 12" flat telephone cables from the RJ11(4) and RJ11(5) and connect one of the telephone cords between RJ11(4) and RJ11(5). This connects the Master AA916 directly to the RM5000.

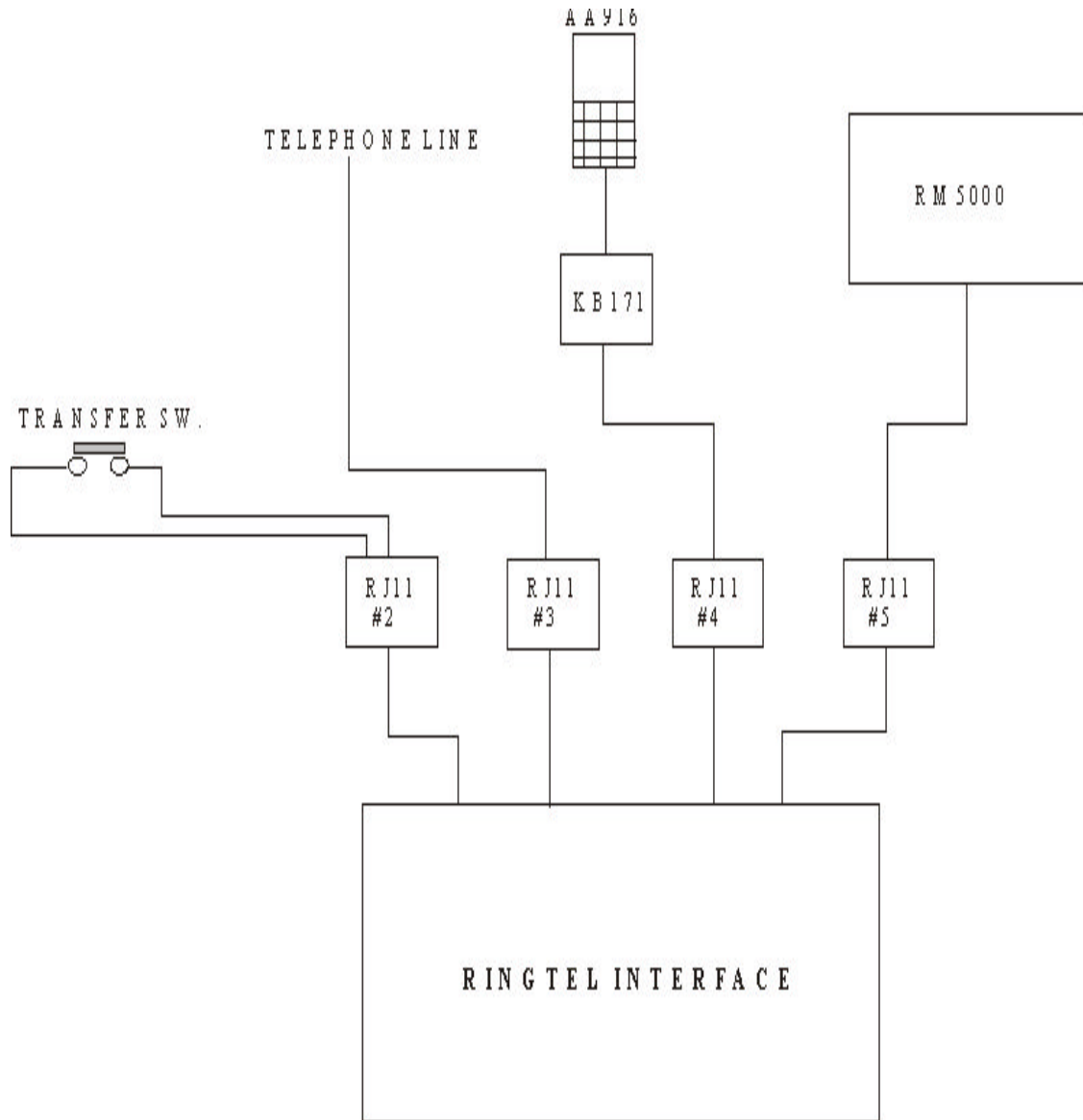

LAYOUT DRAWING FOR RJ11 TERMINAL BOXES FOR RINGTEL INTERFACE

Warranty

Equipment. Minelec Limited warrants for a period of one (1) year from the date of shipment, that any Minelec Limited equipment supplied hereunder shall be free of defects in material and workmanship, shall comply with the then-current product specifications and product literature, and if applicable, shall be fit for the purpose specified in the agreed upon quotation or proposal document. If (a) Seller's goods prove to be defective in workmanship and/or material under normal and proper usage, or unfit for the purpose specified and agreed upon, and (b) Buyer's claim is made within the warranty period set forth above, Buyer may return such goods to Minelec Limited, freight prepaid, at which time they will be repaired or replaced, at Seller's option, without charge to Buyer. Repair or replacement shall be Buyer's sole and exclusive remedy, and the warranty period on any repaired or replacement equipment shall be one (1) year from the date the original equipment was shipped. In no event shall Minelec Limited's warranty obligations with respect to equipment exceed 100% of the total cost of the equipment supplied hereunder.

Buyer may also be entitled to the manufacturer's warranty on any third-party goods supplied by Minelec Limited hereunder. The applicability of any such third-party warranty will be determined by Minelec Limited.

Services. Any services Minelec Limited or their authorized Service Center provides hereunder, whether directly or through subcontractors, shall be performed in accordance with the standard of care with which such services are normally provided in the industry. If the services fail to meet the applicable industry standard, Minelec Limited will, for a period of 90 days from the date of completion, re-perform such services at no cost to Buyer. Re-performance of services shall be Buyer's sole and exclusive remedy, and in no event shall Minelec's warranty obligations with respect to services exceed 100% of the total cost of services provided hereunder.

Warranty Periods. Every claim by Buyer alleging a defect in the goods and/or services provided hereunder shall be deemed waived unless such claim is made in writing within the applicable warranty periods as set forth above. Provided, however, that if the defect complained of is latent and not discoverable within the above warranty periods, every claim arising on account of such latent defect shall be deemed waived unless it is made in writing within a reasonable time after such latent defect is or should have been discovered by Buyer.

Limitations / Exclusions. The warranties herein shall not apply to, and Minelecs nor its authorized Service Centers shall not be responsible for, any damage to the goods or failure of the services supplied hereunder, to the extent caused by Buyer's neglect, failure to follow operational and maintenance procedures provided with the equipment, or the use of technicians not specifically authorized by Minelecs to maintain and or service the equipment.

WARRANTIES AND REMEDIES CONTAINED HEREIN ARE IN LIEU OF AND EXCLUDE ALL OTHER WARRANTIES AND REMEDIES, WHETHER EXPRESS OR IMPLIED BY OPERATION OF LAW OR OTHERWISE, INCLUDING ANY WARRANTIES OF MERCHANTABILITY OR FITNESS FOR A PARTICULAR PURPOSE.

Return Policy

If the equipment requires service within Canada, contact MINELEC LIMITED for a return authorization number (RAN). Equipment should be shipped prepaid to Minelec Limited with a return authorization number and a purchase order number. If the equipment is under warranty, repairs or a replacement will be made by Minelec Limited in accordance with the warranty policy set forth above. Please include a written explanation of all defects to assist their technicians in their troubleshooting efforts.

Call 1-905- 828 1610 and ask for the Minelec Service Desk

Product Design:

We strive to continually improve our products. We therefore reserve the right to alter, without notification, all data in the associated product leaflet.